







Superior handling &
storage solutions

DOLAV ACE 1000

Premium line box pallets



-  Over 1,000,000 in use worldwide
-  Heavy duty box for rough applications
-  Approved for direct contact with food
-  Three integral runners



Strong. Long Lasting. Reliable.

Anti slip corners



A unique stacking system with interlocking plugs allow safe stacking of up to 5000 Kg.

**Box pallets can be supplied with one or two drainage ports, or without a drainage port.

Effective drainage



Built-in 2" drainage ports with caps which are easy to remove **

Perforated version



For fast cooling and ventilation.

Option of 9 feet



Please ask us about this product.

Customised products



Stackable wheels



Opening



Special length SL- 2160



Upper door



Special height SH-440



Special height SH-1250

Local stock available

Looking for fast delivery? For unique colours? For box pallet that will serve you for many years? Dolav has many warehouses in Europe from where we can provide you with the best quality boxes, with local service and support.

Features & Certifications



Certified for UN use (Sweden, France & Israel)



FDA approvals for direct food contact



TÜV SÜD tested



Customised to your needs - height, length, width and accessories available



Large colour range



Fully recyclable



One piece injected mould - including three runners



Easy to repair, if damaged



Rounded interior radius



Easily cleaned



Sturdy and durable for long life span

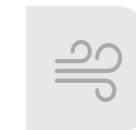

Solid, perforated or combination



RFID-IML Technology

The Power of the Combination: RFID-IML, The DNA of your Dolavs.

- Easier tracking- **Unique ID per Dolav**
- Rewritable Data- Write up to 128 bits of data
- Better documentation - each tag can have high quality printing of both RFID and Barcode
- RFID-IML is more hygienic and avoids contamination
- Long Lasting- RFID IML tags are an integral part of your Dolav and cannot be removed.
- RFID IML tags will not wash or fall off during use.
- RFID IML is washable and withstand -30°C - +100°C
- Can be read from a distance

When you have Dolavs with RFID IML, you have a smarter and efficient stock management system which can help you identify damage in the supply chain and prevent loss.

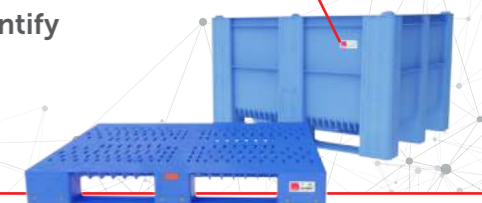

Technical Data

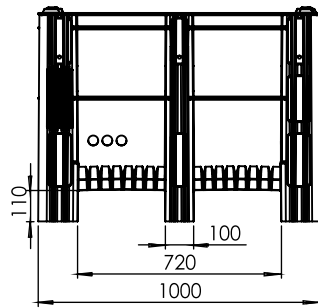
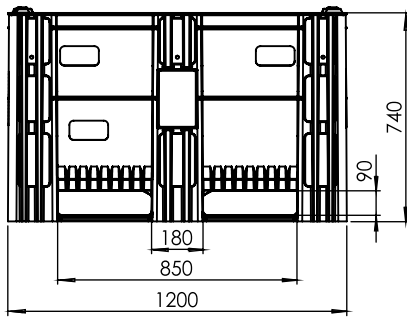

Compatible with 1000 UNIVERSAL lids

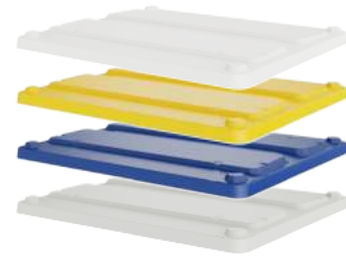

	ACE SOLID - 3 runners	ACE PERFORATED - 3 runners
External dimensions (LxWxH) mm	1200x1000x740	1200x1000x740
Internal dimensions (LxWxH) mm	1128x928x585	1128x928x585
Volume (litre)	605	605
Tare weight (kg)	38.50	37.50
Max load (kg)	1000	1000
Max. stack load (kg)	5000	5000
Raw material	HDPE Structural Foam	
Temperature range	-40°C up to +60°C	
Quantity in container (units)	20'	40' HC
	40	106

Due to deviations in the manufacturing process, tare weight may vary by $\pm 1.5\%$

Dimensions may vary by $\pm 1\%$

Data refers to temperature of 23°C

Maximum stacking load refers to vertical loading when the load per single box pallet does not exceed 750 kg

Maximum load refers to stand alone boxes

Also available with combination: solid walls and perforated base or perforated walls and solid base - minimum order quantity applies

Available with 9 feet - for this option please contact us

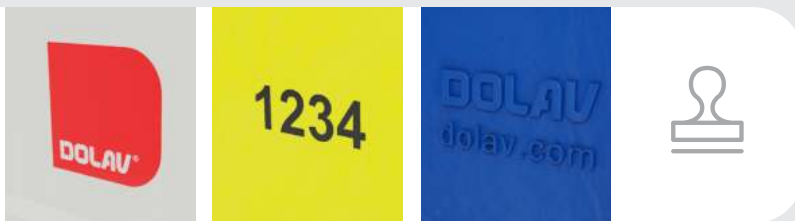

Hot stamped logo

Sequential numbering

Embossed logo

Logo options

The company name, logo and sequential numbers can be hot stamped onto the Dolav for easy identification.

DOLAV[®]

Tried. Trusted. Best.



Dolav Plastic products, Kibbutz Dvir M.P. HaNegev 8533000

☎ 972-72-2450700 🏠 972-8-9918710 ✉ dolav@dolav.com 🌐 www.dolav.com

Worldwide offices: Belgium, China, France, Germany, Hong Kong, Ireland, Israel, Italy, Russia, Spain, The Netherlands, UK, USA

